

How to Order Replacement Parts for South Bend Lathes

This parts list has been prepared especially for the lathe bearing the serial number which appears on the front cover. It should be considered as a part of the lathe equipment and be kept permanently where it will be readily accessible so the correct part numbers can be given when replacement parts are ordered.

The best way to order replacement parts is to send the old part to the factory with the order. This will avoid delay or possible error.

If it is inconvenient to return the old part, be sure to give the following information:

- (1) Serial number of lathe.
- (2) Correct number and name of part.
- (3) Quantity.
- (4) Specify length of wire, cable, conduit, wicking, or hose as the part number does not indicate length.
- (5) Specify dimensions of gasket material as the part number indicates type of material and thickness only.

If the part needed can not be located in this parts list, send a sketch of the part showing all principal dimensions.

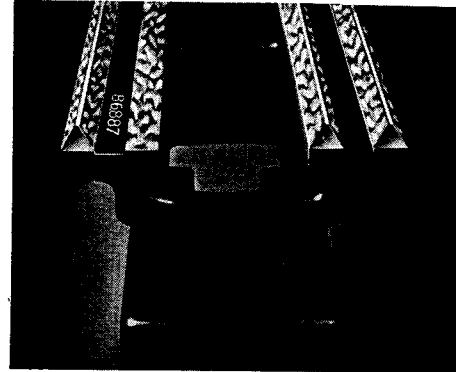

Specify Serial Number of Lathe When Ordering Parts

The serial number of each lathe is stamped on top of the lathe bed between the V-way and flat way at the tailstock end. This number is an index to the size, type, and model of the lathe. Always specify the serial number on each order for replacement parts or attachments.

Terms and Prices

All orders for replacement parts will be shipped C.O.D. unless remittance in full is sent with the order.

All prices are F.O.B. South Bend, Indiana, and will be quoted on request.

Special Instructions

How to Order Gears

When ordering replacement gears, be sure to give all of the information required as listed and illustrated below.

When Ordering Gears Specify—

Serial Number of Lathe	Diameter "D" in Inches
Number and Name of Part	Width "W" in Inches
Quantity	Keyway "K" in Inches
Number of Teeth	Hole "H" in Inches

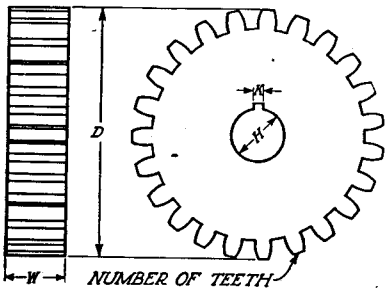

The illustration above shows two views of a gear with parts lettered for use when indicating specifications on your order.

How to Order Threaded Parts

When ordering threaded parts, other than commercial parts such as standard screws, bolts, and nuts, be sure to give all of the information required as listed below.

When Ordering Threaded Parts Specify—

Serial Number of Lathe	Number of Threads per Inch
Number and Name of Part	Kind of Thread:
Quantity	Acme Thread
Outside Diameter of	U. S. Standard Thread
Threads in Inches	Sharp "V" Thread
	Right-or Left-hand Thread

Repair Parts Supplied for South Bend Lathes Only

The lathe parts listed in this parts list can be supplied only for use on South Bend Lathes. We are not in a position to supply parts for other makes of lathes or for use on jigs, fixtures, special machines or equipment.

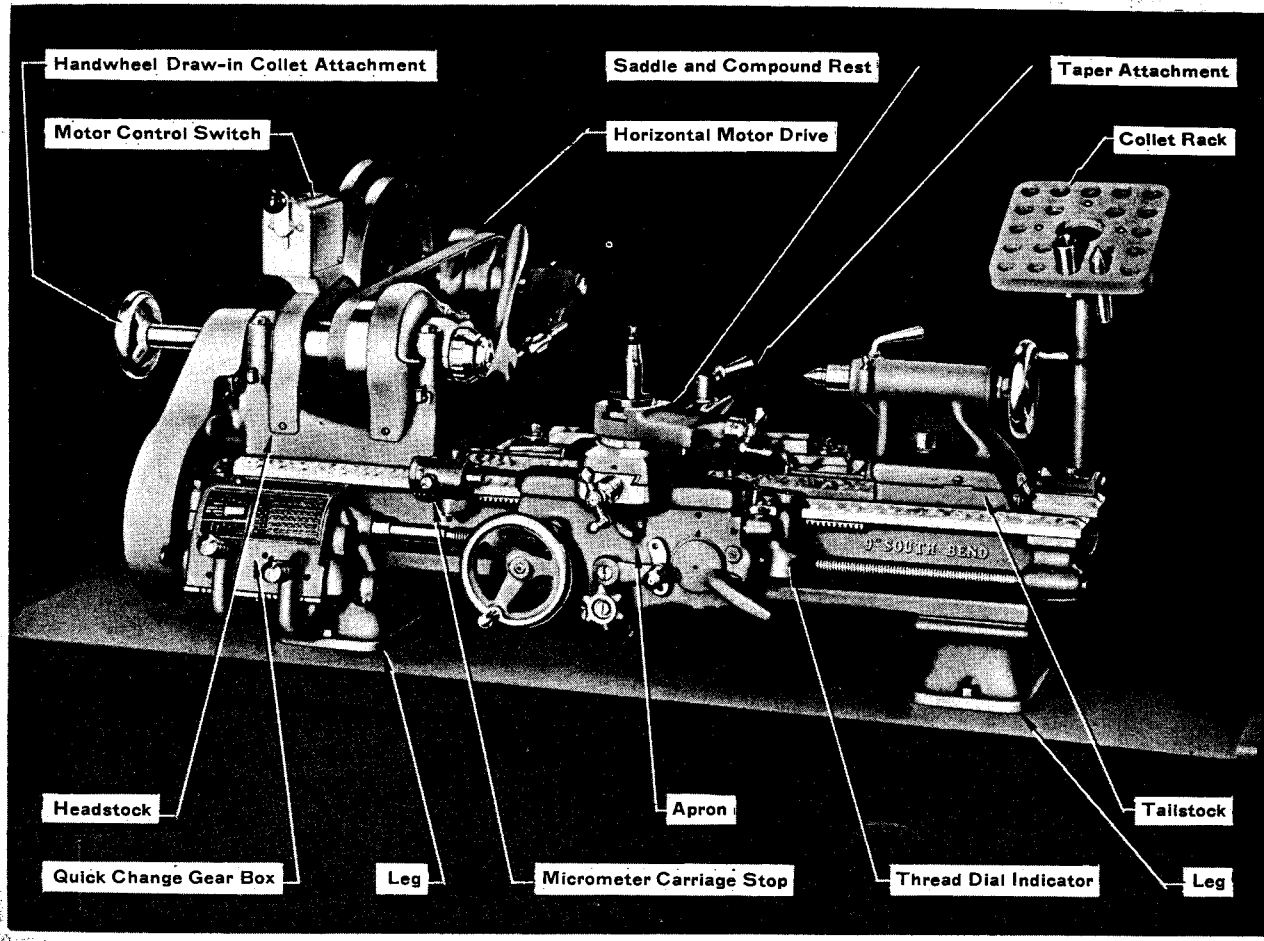

PARTS LIST No. P-8644

for

9-inch Model A

**12-Speed Horizontal Motor Drive
South Bend Toolroom Bench Lathe**

Unit	Page	Unit	Page
Headstock	2	Motor Control Switch	9
Quick Change Gear Box	3	Taper Attachment	10
Saddle and Compound Rest	4	Handwheel Draw-in Collet Attachment ..	11-A
Apron	5	Collet Rack	11-A
Horizontal Motor Drive	6	Micrometer Carriage Stop	12
Tailstock	7	Thread Dial Indicator	12
Legs	8	Thread Cutting Stop	12

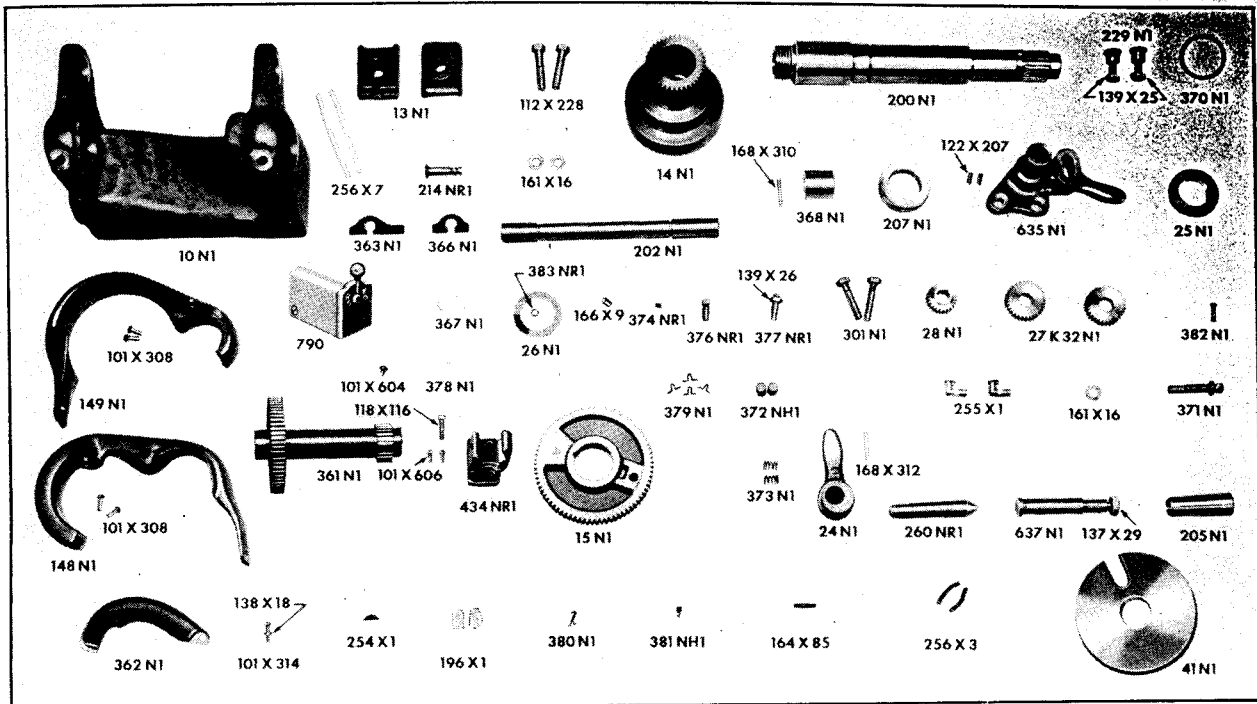

Headstock Parts

Part No.	Name of Part
10N1	Headstock
13N1	Headstock Clamps
14N1	Spindle Cone
15N1	Bull Gear
24N1	Back Gear Lever
25N1	Spindle Take-up Nut
26N1	Spindle Take-up Nut Washer
27K32N1	Reverse Twin Gears
28N1	Reverse Gear
41N1	Face Plate
101X308	Bull Gear Guard Screws
101X308	Quill Gear Guard Screws
101X314	Bull Gear Plunger Guard Screw
101X604	Back Gear Oil Hole Screw
101X606	Motor Control Switch Screws
112X228	Headstock Clamp Screws
118X116	Motor Control Switch Bracket Set Screw
122X207	Reverse Bracket Set Screws
137X29	Reverse Shaft Nut
138X18	Bull Gear Plunger Guard Nut
139X25	Twin Gear Stud Nuts
139X26	Back Gear Lever Stop Screw Nut
148N1	Quill Gear Guard
149N1	Bull Gear Guard
161X16	Headstock Clamp Screw Washers
161X16	Reverse Bracket Collar Screw Washer
164X85	Reverse Shaft Key
166X9	Back Gear Spring Shoe
168X310	Eccentric Shaft Bushing Pin
168X312	Back Gear Lever Pin
192X21	Drum Switch for 115 Volt A.C.
196X1	Spindle Bearing Capillary Oiler Wool
200N1	Headstock Spindle
202N1	Eccentric Shaft
205N1	Spindle Sleeve

Part No.	Name of Part
207N1	Spindle Bearing Ball Thrust Bearing
214NR1	Bull Gear Plunger
229N1	Twin Gear Studs
254X1	Bull Gear Key
255X1	Headstock Oilers
256X3	Reverse Bracket Felt Wick, Flat
256X7	Reverse Twin Gear Stud Felt Wick, Round
260NR1	Headstock Center
301N1	Headstock Cap Screws
361N1	Back Gears
362N1	Bull Gear Plunger Guard
363N1	Headstock Shim—Large (Brass)
364N1	Headstock Shim—Large (Zinc)
365N1	Headstock Shim—Small (Brass)
366N1	Headstock Shim—Small (Zinc)
367N1	Bull Gear Plunger Spring
368N1	Eccentric Shaft Bushing
370N1	Spindle Bearing Protecting Ring
371N1	Reverse Bracket Collar Screw
372NH1	Spindle Bearing Capillary Oiler Felt
373N1	Spindle Bearing Capillary Oiler Spring
374NR1	Back Gear Spring
376NR1	Back Gear Spring Set Screw
377NR1	Back Gear Lever Stop Screw
378N1	Back Gear Oil Hole Washer
379N1	Spindle Bearing Oil Return Clips (Small)
380N1	Spindle Bearing Oil Return Clip (Large)
381NH1	Cone Pulley Oil Hole Plug Screw
382N1	Spindle Take-up Nut Screw
383NR1	Spindle Take-up Nut Washer Pin
434NR1	Motor Control Switch Bracket
635N1	Reverse Bracket
637N1	Reverse Shaft
790	Drum Switch for 220-550 Volt A.C. and all D.C.

SOUTH BEND LATHE WORKS

SOUTH BEND 22, INDIANA, U.S.A.

Quick Change Gear Box Parts

(See List of Parts on Other Side of This Sheet)

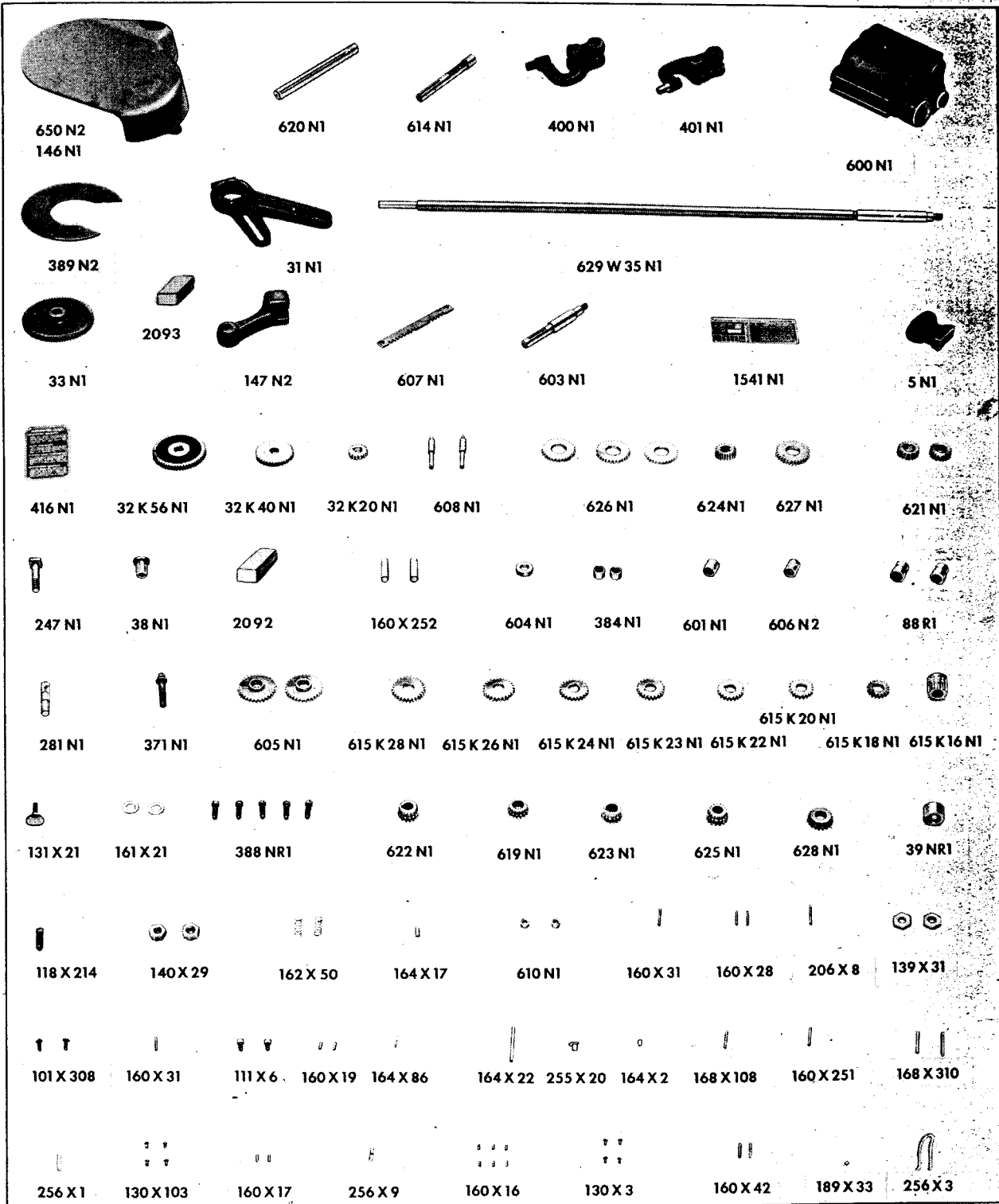

Quick Change Gear Box Parts

(See Illustration of Parts on Other Side of This Sheet)

Part No.	Name of Part	Part No.	Name of Part
5N1	Rear Lead Screw Bracket.....	256X3	Gear Box Felt Wick, Flat.....
31N1	Change Gear Bracket.....	256X3	Main Drive Shaft Wicking.....
32K20N1	Change Gear—20 Teeth.....	256X9	Wired Cotton Wicking for Gear Box.....
32K40N1	Change Gear—40 Teeth.....	281N1	Stud, Change Gear Guard.....
32K56N1	Change Gear—56 Teeth.....	371N1	Collar Screw, Change Gear Bracket.....
33N1	Idler Gear.....	384N1	Tumbler Idler Gear Bearings.....
38N1	Idler Gear Bushing.....	388NR1	Screws, Gear Box.....
39NR1	Lead Screw Thrust Collar.....	388NR1	Screws, Lead Screw Bracket.....
88R2	Tumbler Plunger Knobs.....	389N2	Change Gear Safety Guard.....
101X308	Screws, Change Gear Safety Guard.....	400N1	Gear Box Tumbler (Right).....
111X6	Screws, Tumbler Guide Bar.....	401N1	Gear Box Tumbler (Left).....
118X214	Set Screw, Gear Guard Bracket.....	416N1	Lubrication Chart.....
130X3	Escutcheon Pins, Lubrication Chart.....	600N1	Gear Box.....
130X103	Escutcheon Pins, Index Plate.....	601N1	Cone Gear Shaft Bushing.....
131X21	Thumb Screw, Gear Guard Bracket.....	603N1	Main Drive Shaft.....
139X31	Nuts, Lead Screw.....	604N1	Main Drive Shaft Collar.....
140X29	Nut, Idler Gear Bolt.....	605N1	Tumbler Idler Gears.....
140X29	Nut, Main Drive Shaft.....	606N2	Main Drive Shaft Bushing.....
146N1	Change Gear Guard for Horizontal Motor Driven Lathes.....	607N1	Tumbler Guide Bar.....
147N2	Change Gear Guard Bracket.....	608N1	Tumbler Plungers.....
160X16	Pins, Small Compound Gear (Cone Gear Shaft)	610N1	Plunger Bushings.....
160X16	Pins, Small Compound Gear (Main Drive Shaft)	614N1	Cone Gear Shaft.....
160X16	Pins, Tumbler Comp. Gear (Cone Gear Shaft)	615K16N1	Cone Gear—16 Teeth.....
160X17	Pin, Large Compound Gear (Main Drive Shaft)	615K18N1	Cone Gear—18 Teeth.....
160X17	Pin, Small Compound Gear (Main Drive Shaft)	615K20N1	Cone Gear—20 Teeth.....
160X19	Pins, Tumbler Guide Bar.....	615K22N1	Cone Gear—22 Teeth.....
160X28	Pins, Tumbler Plunger.....	615K23N1	Cone Gear—23 Teeth.....
160X31	Pin, Main Drive Shaft Bushing.....	615K24N1	Cone Gear—24 Teeth.....
160X42	Pins, Tumbler.....	615K26N1	Cone Gear—26 Teeth.....
160X251	Pin, Cone Gear.....	615K28N1	Cone Gear—28 Teeth.....
160X252	Tumbler Idler Gear Shafts.....	619N1	Small Compound Gear (Main Drive Shaft)....
160X252	Pin, Cone Gear.....	620N1	Main Pinion Shaft.....
161X21	Washer, Idler Gear Bolt.....	621N1	Tumbler Gears.....
161X21	Washer, Main Drive Shaft.....	622N1	Tumbler Compound Gear (Cone Gear Shaft)...
162X50	Springs, Tumbler Plunger Knob.....	623N1	Small Compound Gear (Cone Gear Shaft)....
164X2	Key, Lead Screw.....	624N1	Cone Shaft Gear.....
164X17	Key, Main Drive Shaft (Large).....	625N1	Small Compound Gear (Main Drive Shaft)....
164X22	Key, Cone Gear Shaft.....	626N1	Large Compound Gears (Cone Gear Shaft)...
164X86	Key, Main Drive Shaft (Small).....	627N1	Large Compound Gear (Main Drive Shaft)....
168X108	Pin, Main Drive Shaft Collar.....	628N1	Lead Screw Gear.....
168X310	Pin, Cone Gear.....	629W3N1	Lead Screw for 3-foot Bed.....
168X310	Pin, Lead Screw Thrust Collar.....	629W35N1	Lead Screw for 3½-foot Bed.....
189X33	Gear Box Expansion Plug.....	629W4N1	Lead Screw for 4-foot Bed.....
206X8	Tumbler Pinion Shaft.....	629W45N1	Lead Screw for 4½-foot Bed.....
247N1	Bolt, Idler Gear.....	650N2	Change Gear Guard for Underneath Motor Driven Lathes.....
255X20	Gear Box Oiler.....	1541N1	Index Plate.....
256X1	Cone Gear Shaft Wicking.....	2092	Babbitt for Rear Lead Screw Bracket.....
256X1	Tumbler Pinion Shaft Wicking.....	2093	Babbitt for Change Gear Guard Bracket.....

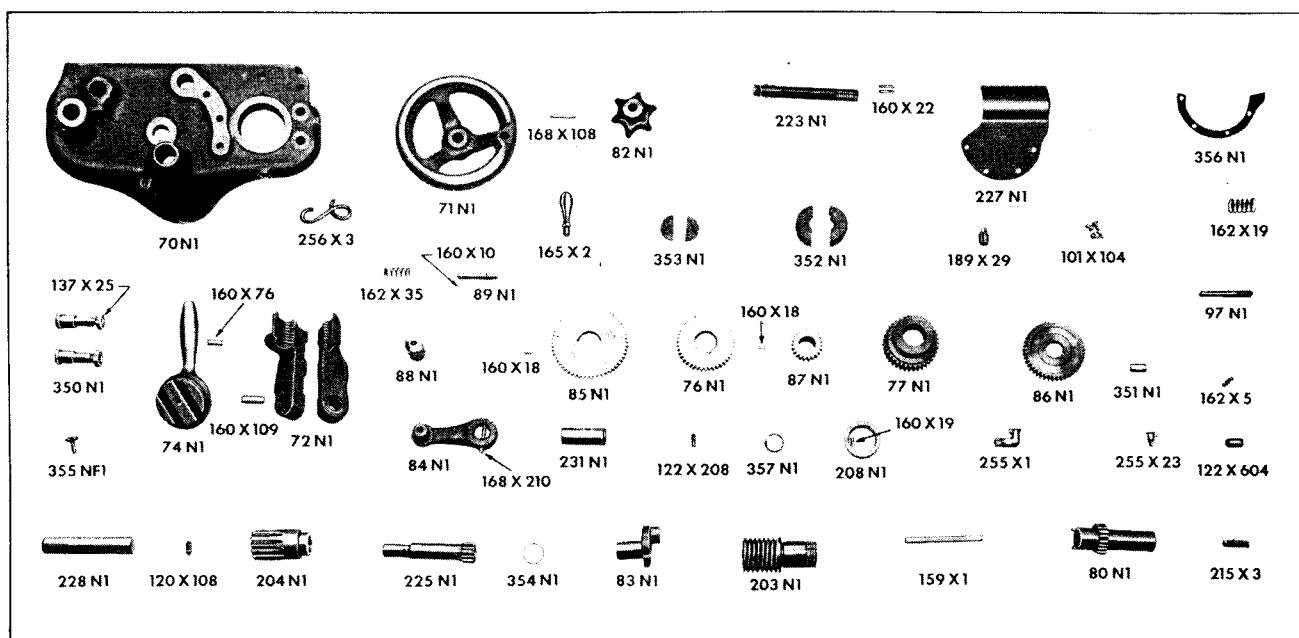

Apron Parts

Part No.	Name of Part
70N1	Apron
71N1	Handwheel
72N1	Half-Nuts
74N1	Half-Nut Cam
76N1	Rack Pinion Gear
77N1	Worm Gear
80N1	Clutch Sleeve
82N1	Clutch Knob
83N1	Idler Gear Shifter
84N1	Idler Gear Shifter Lever
85N1	Cross-Feed Compound Gear
86N1	Idler Gear
87N1	Cross-Feed Compound Pinion
88N1	Idler Gear Shifter Knob
89N1	Idler Gear Shifter Plunger
97N1	Feed Interlock Plunger
101X104	Oil Trough Screws
120X108	Rack Pinion Stud Set Screw
122X208	Cross-Feed Compound Gear Shaft Set Screw
122X604	Cam Retainer Pin Set Screw
137X25	Half-Nut Stud Nuts
159X1	Worm Key
160X10	Idler Gear Shifter Plunger Pin
160X18	Cross-Feed Compound Pinion Pin
160X18	Rack Pinion Gear Pin
160X19	Worm Collar Pin
160X22	Clutch Screw Pin
160X76	Half-Nut Cam Stop Pin

Part No.	Name of Part
160X109	Half-Nut Pins
162X5	Cam Retainer Spring
162X19	Clutch Sleeve Spring
162X35	Shifter Plunger Spring
165X2	Handwheel Handle
168X108	Handwheel Pin
168X210	Idler Gear Shifter Lever Pin
189X29	Reservoir Plug
203N1	Apron Worm
204N1	Rack Pinion
208N1	Worm Collar
215X3	Half-Nut Oil Tube
223N1	Clutch Screw
225N1	Handwheel Pinion
227N1	Oil Trough
228N1	Rack Pinion Stud
231N1	Cross-Feed Compound Gear Shaft
255X1	Reservoir Oiler
255X23	Handwheel Oiler
256X3	Apron Worm Oil Wick
350N1	Half-Nut Studs
351N1	Half-Nut Cam Retainer Pin
352N1	Clutch Shoe
353N1	Clutch Shoe Expander
354N1	Handwheel Pinion Spring
355NF1	Clutch Knob Screw
356N1	Oil Trough Gasket
357N1	Cross-Feed Compound Gear Shaft Spring

SOUTH BEND LATHE WORKS

SOUTH BEND 22, INDIANA, U.S.A.

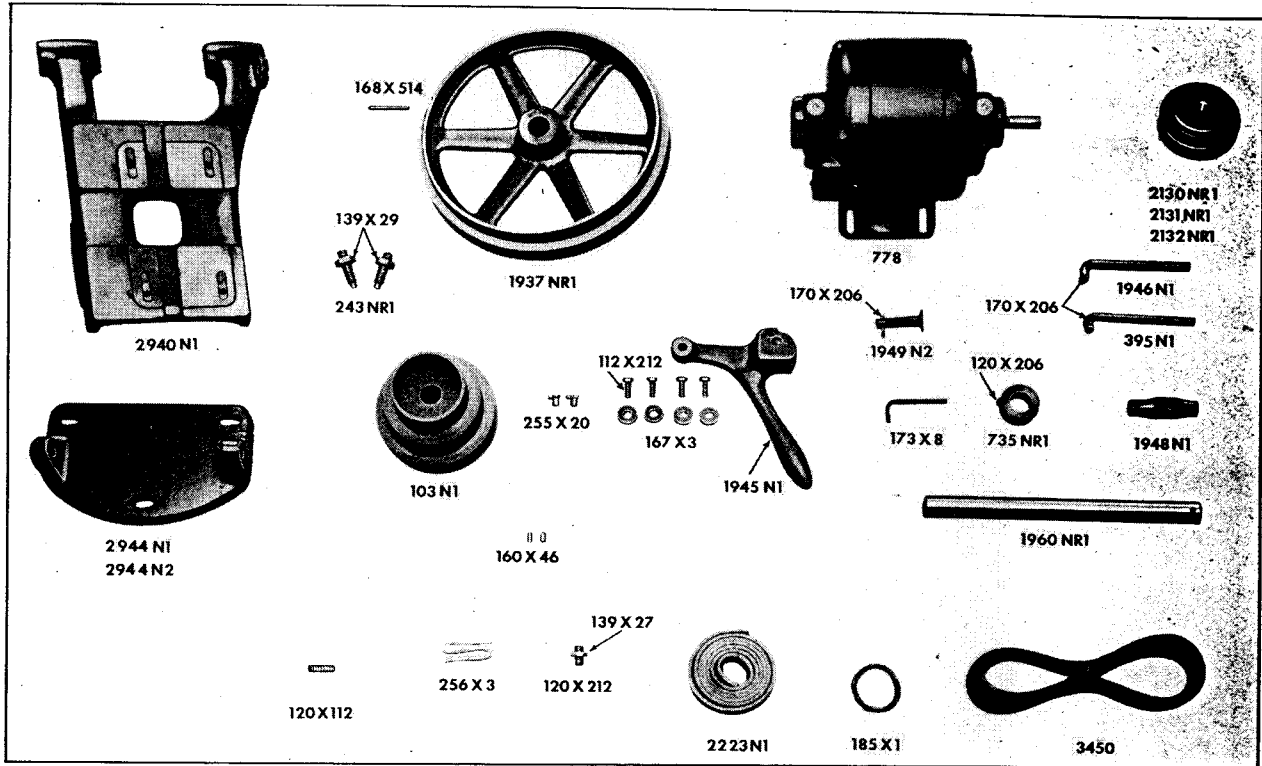

Horizontal Motor Drive Parts

(12 Speed—Flat Belt Drive—½ h.p. Motor)

Part No.	Name of Part	Part No.	Name of Part
103N1	Countershaft Cone Pulley	735NR1	Countershaft Collar
112X212	Screws, Motor Mounting	778	Motor ½ h.p. (State make, voltage, r.p.m., cycle, phase, and whether A.C. or D.C.)
120X112	Set Screw, Motor Pulley	1937NR1	Double Drive Pulley
120X206	Set Screw, Countershaft Collar	1945N1	Belt Release Lever
120X212	Set Screw, Cone Pulley	1946N1	Belt Release Rod, Front
139X27	Nut, Cone Pulley Set Screw	1948N1	Turnbuckle
139X29	Nuts, Motor Standard Pivot Screw	1949N2	Pin, Belt Release Lever
160X46	Pins, Motor Standard	1960NR1	Motor Pulley Shaft
167X3	Washers, Motor Mounting Screw	2130NR1	Combination Motor Pulley for ½" Shaft
168X514	Taper Pin, Countershaft Drive Pulley	2131NR1	Combination Motor Pulley for ⅝" Shaft
170X206	Cotter Pins, Belt Release Rod	2132NR1	Combination Motor Pulley for ¾" Shaft
170X206	Cotter Pin, Belt Release Lever Pin	2223N1	Flat Leather Belt
173X8	Wrench, Set Screw	2940N1	Motor Standard
185X1	Belt Lacing	2944N2	Motor Standard Base For Master Motors
243NR1	Screws, Motor Standard Pivot	2944N1	Motor Standard Base For all other Motors
255X20	Oilers, Countershaft Bearing	3450	V-Belt, Motor to Countershaft
256X9	Felt Wicks, Countershaft Bearing Oiler		
395N1	Belt Release Rod, Rear		

SOUTH BEND LATHE WORKS

SOUTH BEND 22, INDIANA, U.S.A.

Handlever Turret Parts

(See List of Parts on Other Side of This Sheet)

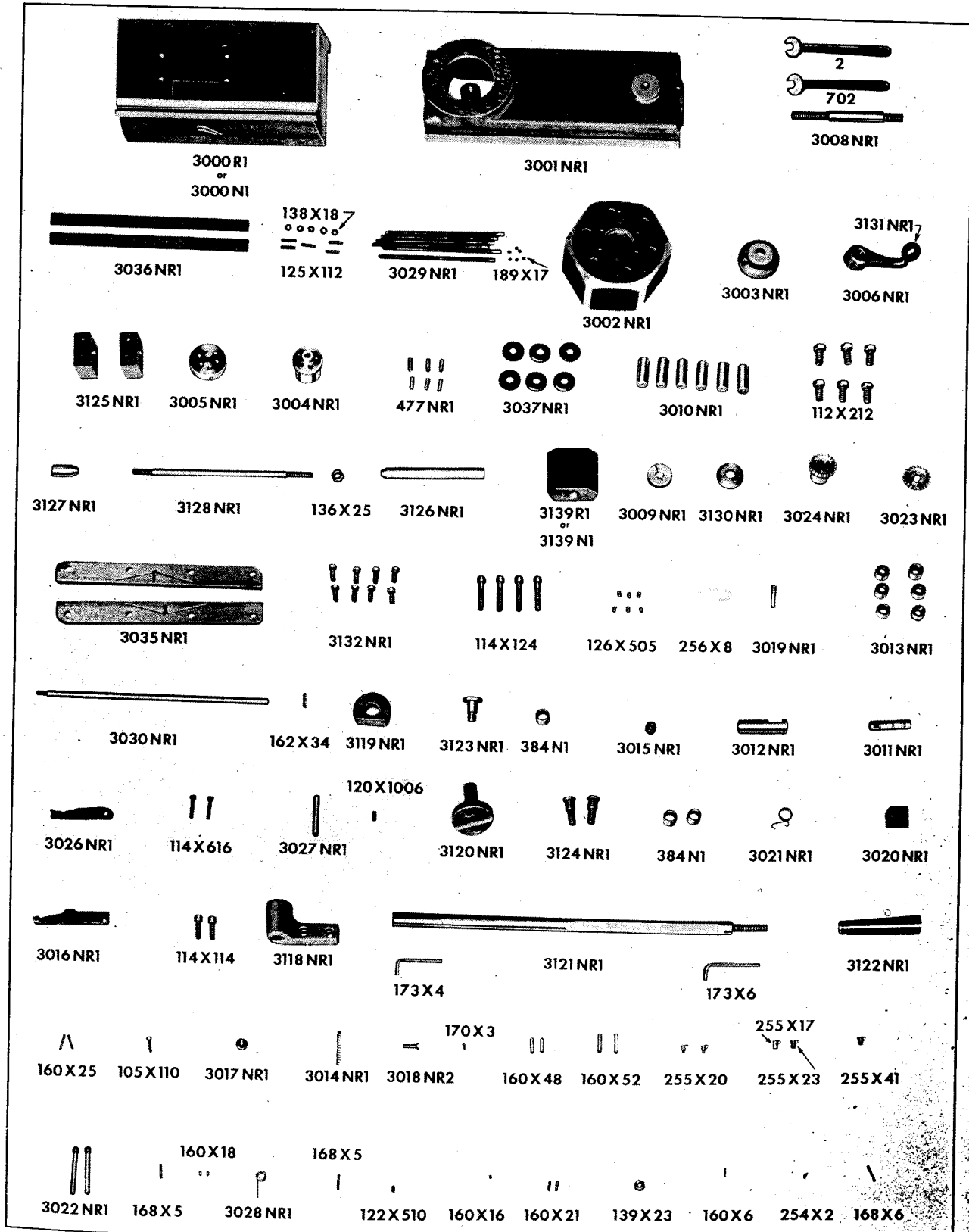

Handlever Turret Parts

(See Illustration of Parts on Other Side of This Sheet)

Part No.	Name of Part	Part No.	Name of Part
2	Clamp Rod Nut Wrench	3003NR1	Turret Head Clamp
105X110	Screw, Stud Adjusting Nut	3004NR1	Stop Screw Index
112X212	Bolts, Tool Binder	3005NR1	Stop Screw Index End Plate
114X114	Screws, Handlever Bracket	3006NR1	Clamping Lever
114X124	Screws, Cone Bearing	3008NR1	Turret Stud
114X616	Screws, Swivel	3009NR1	Adjusting Nut, Turret Stud
120X1006	Set Screw, Turret Stud	3010NR1	Tool Binders
122X510	Set Screw, Clamping Lever	3011NR1	Lock Bolt
125X112	Screws, Side Gib	3012NR1	Lock Bolt Bushing
126X505	Screws, Stop Screw Index End Plate	3013NR1	Lock Bolt Indexing Bushings
136X25	Nut, Clamp Rod	3014NR1	Spring, Lock Bolt
138X18	Nuts, Side Gib Screw	3015NR1	Lock Bolt Spring Retainer
139X23	Nut, Stop Screw Index Shaft	3016NR1	Lock Bolt Lever
160X6	Pin, Front Cone	3017NR1	Lock Bolt Lever Roller
160X16	Key, Front Cone Bearing	3018NR2	Pin, Lock Bolt Lever Roller
160X18	Pins, Side Gib	3019NR1	Pivot Pin, Lock Bolt Lever
160X21	Pin, Index Lever Spring	3020NR1	Lock Bolt Cam
160X21	Pin, Turret Head Gear	3021NR1	Spring, Lock Bolt Cam
160X25	Pins, Stop Screw Index End Plate	3022NR1	Pivot Pins, Lock Bolt Cam
160X48	Stop Pin, Index Lever	3023NR1	Turret Head Gear
160X48	Pin, Lock Bolt Cam	3024NR1	Stop Screw Gear
160X52	Pins, Handlever Bracket	3026NR1	Indexing Lever
162X34	Spring, Lock Bolt Lever	3027NR1	Pivot Pin, Index Lever
168X5	Pin, Indexing Lever	3028NR1	Spring, Index Lever
168X5	Index Pin, Stop Screw	3029NR1	Stop Screws
168X6	Pin, Stop Screw Gear	3030NR1	Stop Screw Index Shaft
170X3	Cotter Pin, Lock Bolt Lever Roller Pin	3035NR1	Horizontal Gibs
173X4	Side Gib Screw Wrench	3036NR1	Side Gibs
173X6	Stop Screw Index End Plate Screw Wrench	3037NR1	Washers, Tool Binder Bolt
189X17	Stop Screw Index End Plate Screw Shoes	3118NR1	Handlever Bracket
254X2	Key, Turret Stud	3119NR1	Swivel
255X17	Oiler, Stop Screw Index	3120NR1	Swivel Hinge
255X20	Oilers, Horizontal Gib	3121NR1	Handlever
255X23	Oiler, Index Shaft	3122NR1	Handlever Handle
255X41	Oiler, Turret Head Clamp	3123NR1	Stud, Swivel
256X8	Turret Base Felt Wick	3124NR1	Stud, Swivel Hinge
384N1	Swivel Bearing	3125NR1	Cone Bearings
384N1	Swivel Hinge Stud Bearings	3126NR1	Rear Cone
477NR1	Indexing Pins, Turret Head	3127NR1	Front Cone
702	Tool Binder Bolt Wrench	3128NR1	Clamp Rod
3000N1	Turret Base for 9" Lathes	3130NR1	Turret Stud Guide
3000R1	Turret Base for 10" Lathes	3131NR1	Clamping Lever Handle
3001NR1	Turret Ram	3132NR1	Screws, Horizontal Gib
3002NR1	Turret Head	3139N1	Turret Base Clamp for 9" Lathes
		3139R1	Turret Base Clamp for 10" Lathes

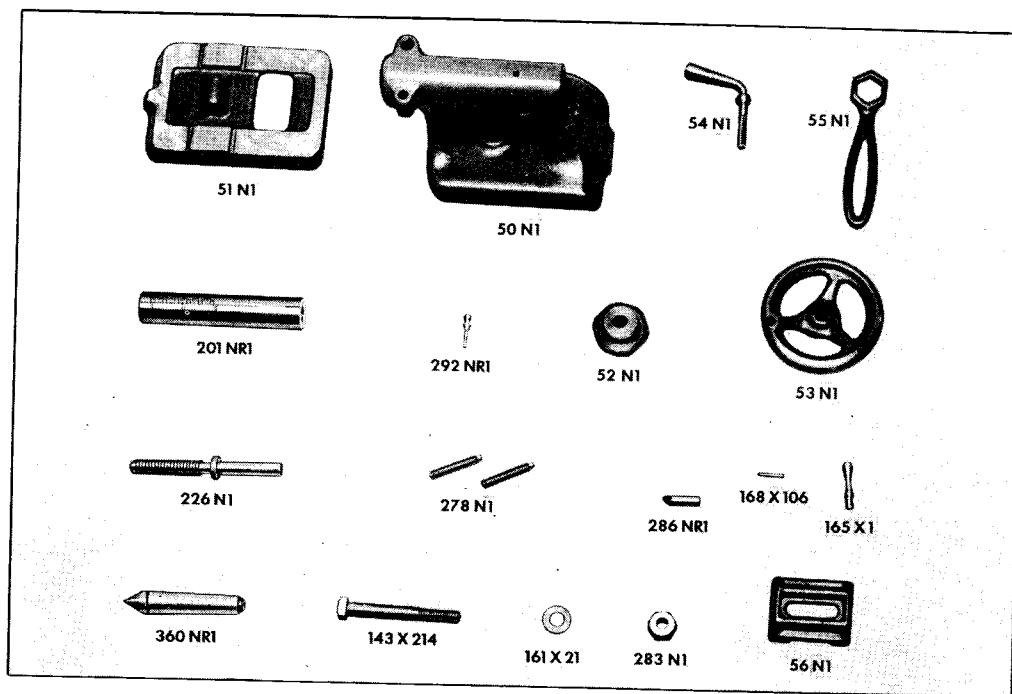

Tailstock Parts

Part No.	Name of Part
50N1	Tailstock Top
51N1	Tailstock Base
52N1	Tailstock Nut
53N1	Tailstock Handwheel
54N1	Tailstock Binding Lever
55N1	Tailstock Wrench
56N1	Tailstock Clamp
143X214	Tailstock Clamp Bolt
161X21	Clamp Bolt Washer

Part No.	Name of Part
165X1	Tailstock Handwheel Handle
168X106	Tailstock Handwheel Pin
201NR1	Tailstock Spindle
226N1	Tailstock Screw
278N1	Tailstock Set-Over Screws
283N1	Tailstock Clamp Bolt Nut
286NR1	Tailstock Spindle Key
292NR1	Oil Reservoir Plug
360NR1	Tailstock Center

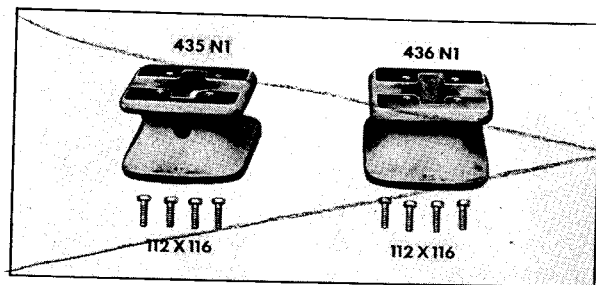

Bench Legs

Part No.	Name of Part
112X116	Leg to Bed Screws (4 to each leg)
435N1	Bench Leg (Headstock end)
436N1	Bench Leg (Tailstock end)

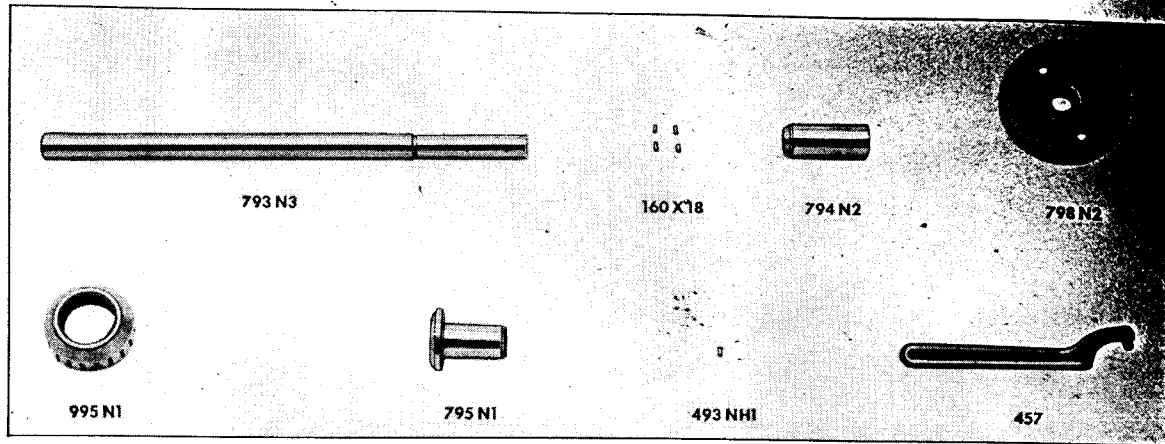

Handwheel Draw-in Collet Attachment Parts

Part No.	Name of Part
160X18	Pins, Draw Tube Sleeve.....
160X18	Pins, Handwheel.....
457	Wrench, Spindle Nose Cap.....
493NH1	Key, Collet Sleeve.....
793N3	Draw Tube.....

Part No.	Name of Part
794N2	Sleeve, Draw Tube.....
795N1	Sleeve, Collet.....
798N2	Handwheel.....
995N1	Spindle Nose Cap.....

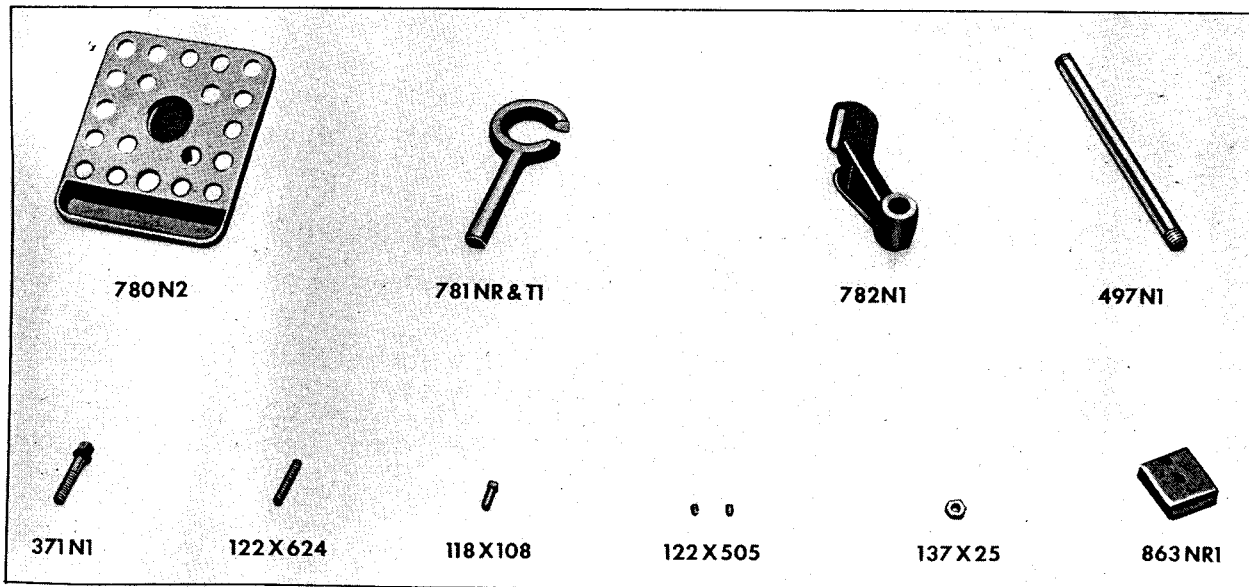

Collet Rack Parts

Part No.	Name of Part
118X108	Set Screw, Draw Tube Hook.....
122X505	Set Screws, Rack.....
122X624	Set Screw, Collet Rack Bracket Clamp.....
137X25	Nut, Collet Rack Bracket Clamp Set Screw.....
371N1	Screw, Collet Rack Bracket Clamp.....

Part No.	Name of Part
497N1	Rack Pipe.....
780N2	Rack.....
781NR&T1	Draw Tube Hook.....
782N1	Collet Rack Bracket.....
863NR1	Collet Rack Bracket Clamp.....

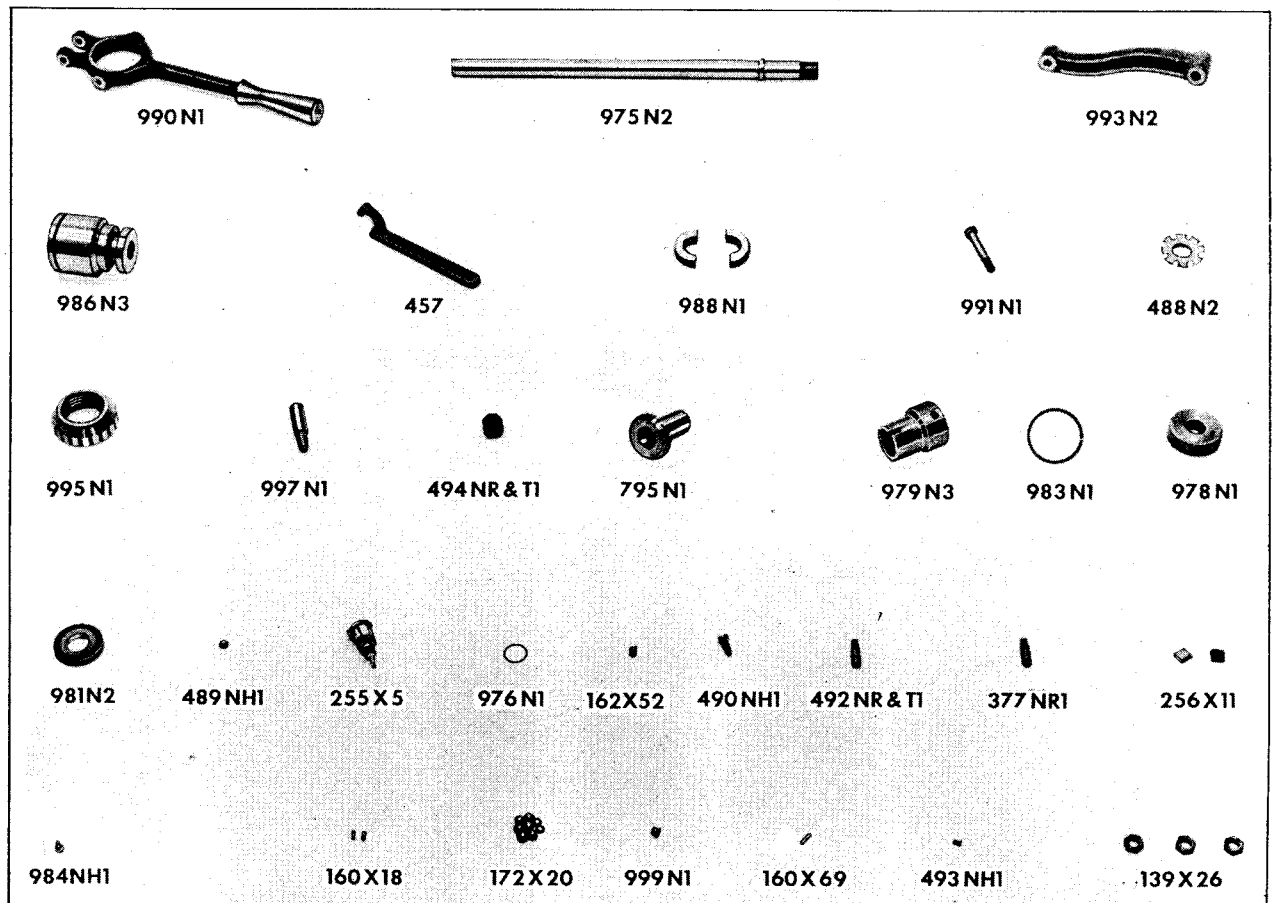

Handlever Draw-in Collet Attachment Parts

Part No.	Name of Part	Part No.	Name of Part
139X26	Nut, Cam Yoke Lever Screw	795N1	Collet Sleeve
139X26	Nuts, Cam Yoke Bolt	975N2	Draw Tube
160X18	Pins, Cam Yoke Ring Sector	976N1	Draw Tube Snap Ring
160X69	Pin, Clutch Sleeve	978N1	Cam Stop Nut
162X52	Spring, Cam Sleeve	979N3	Cam Sleeve
172X20	Cam Balls	981N2	Draw Tube Collar
255X5	Oiler	983N1	Yoke Snap Ring
256X11	Felt Wick	986N3	Cam Yoke Cone
377NR1	Stop Screw, Cam Sleeve	988N1	Cam Yoke Ring Sectors
457	Spindle Nose Cap Wrench	990N1	Cam Yoke Lever
488N2	Cam Ball Retainer	991N1	Bolt, Cam Yoke
489NH1	Screw, Cam Sleeve	993N2	Cam Yoke Lever Bracket
490NH1	Screw, Cam Stop Nut	995N1	Spindle Nose Cap
492NR&T1	Screw, Cam Yoke Lever	997N1	Stud, Cam Yoke Lever Bracket
493NH1	Key, Collet Sleeve	999N1	Key, Cam Adjustment Sleeve
494NR&T1	Nut, Cam Yoke Lever Screw		