

Di-Acro®

OPERATOR'S MANUAL & INSTRUCTIONS

PUNCH TOOLING



Di-Acro, Incorporated
PO Box 9700
Canton, Ohio 44711
3713 Progress Street N.E.
Canton, Ohio 44705
330-455-1942
330-455-0220 (fax)
Revised 01/02

INDEX

- 901 SERIES -Interchangeability Capabilities
 -General Information, Single Station Punch Pak
 -Single Station Punches and Dies
 -Die Holders, Die Adapters, Punch Holders
- 902 SERIES -General Information, Punch Holders, Die Holders, Metal Strippers
 -Non-Keyed Turret Punches and Dies
- 903 SERIES -General Information, Punch Holders, Die Holders, Turret Specifications
 -Keyed Turret Punches and Dies
- 905 SERIES -General Information, Adjustable Punches and Dies
 - Adjustable Punch and Die Holders

MINIMUM ORDER \$ 50.00

INTERCHANGEABILITY **901 SERIES** CAPABILITIES

Di-Acro punches and dies will accommodate W.A. Whitney presses that use No. 2 and 28 Whitney tooling. The 901 Series also fits Roper Whitney presses that utilize No. 8 and 28 tooling. This series will comply with many types of punching equipment of other manufacturers.

SINGLE STATION PUNCHES

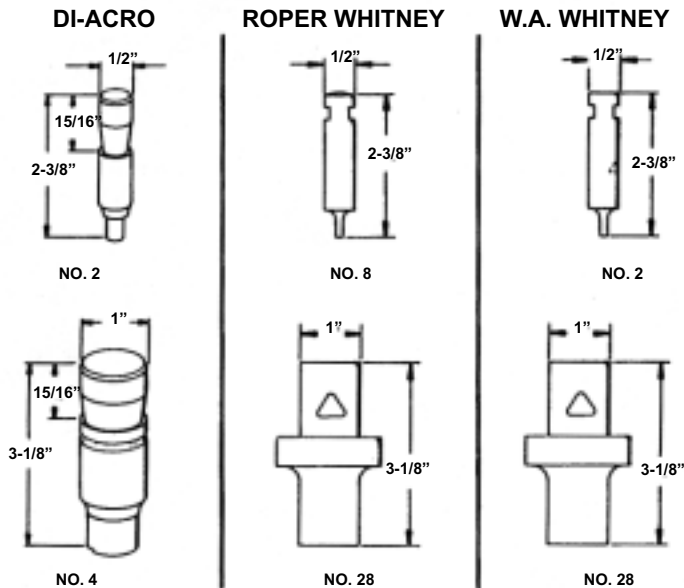

SINGLE STATION DIES

	DI-ACRO	ROPER WHITNEY
A		NO. 20
B		NO. 40
C		NO. 28
D		NO. 28
E		NO. 28

DI-ACRO SINGLE STATION 901 SERIES PUNCHES & DIES



Di-Acro single station tools are designed for use in Di-Acro single station punch presses No. 1 and 2.

TWIN SHEAR- All punches requiring more than 4 tons to punch 16 gauge mild steel (13/16 round or equivalent irregular size) are ground with twin shear. Twin shear reduces necessary power about 50%. Punches 13/16" or larger are also available without twin shear. Consult Factory for pricing.

CENTER POINT- All single station punches from 1/8" and up are provided with a centering point. This feature is best suited for accurate layout work, or for hole location. Additional charge to remove center point.

CLEARANCE- Single station punches and dies are provided with a standard clearance of .007" - .008" (15% of 16 ga. material). Special clearances greater than .004" Can be supplied at no additional cost.

BLANKING DIES-In operations where the slug must be retained, Di-Acro can furnish the punch and die set to your specifications. For blanking, the punch is ground flat.

DI-ACRO SINGLE STATION PUNCHES ARE MANUFACTURED IN TWO STYLES:



#2 Punch

PUNCH NO. 2-Made to a maximum of 1/2" round or a shape that is within the perimeter of 1/2" diameter.

PUNCH NO. 4-Made from 1/2" to a maximum of 4" round, or a shape that is within the perimeter of 4" diameter.

SINGLE STATION PUNCH PAKS- 901 SERIES

Punch Paks are assortments of commonly-used punches and dies stored in hard metal containers. These Punch Paks eliminate production delays, save lost time looking for the right sizes, or having to order special.

PUNCH PAK NO. 1-contains 30 sizes of round punches and dies, 3/64" through 1/2" in increments of 1/64". Net Wt. 13lbs., Ship Wt. 18lbs.

CAT NO.
902802-000



PUNCH PAK NO. 2-contains 8 rounds, in sizes 1/16" through 1/2" in increments of 1/16"; 12 rounds, in sizes 1/2" through 2" in increments of 1/8"; 4 squares, in 1/2", 5/8", 3/4" and 1". Net Wt. 38 lbs. Ship Wt. 45 lbs.

CAT NO.
901802-000

901 SERIES SINGLE STATION PUNCHES & DIES

SINGLE STATION PUNCHES

ROUND

PUNCHES

DIES

STYLE	SIZE	CAT. NO.	STYLE	MAX DIAM.	O.D.	CAT. NO.
2	.063" -- .500"	901009-000	A	.508"	1.250"	901030-000
4	.501" – 1.000"	901010-000	A	.758"	1.250"	901030-000
4	1.001" – 1.437"	901011-000	B	1.445"	2.125"	901032-000
4	1.438" – 2.000"	901012-000	C	2.008"	2.750"	901034-000
4	2.001" – 2.500"	901013-000	D	2.508"	3.750"	901036-000
4	2.501" – 3.000"	901014-000	D	3.008"	3.750"	901036-000
4	3.001" – 3.500"	901015-000	E	3.508"	4.750"	901038-000
4	3.501" – 4.000"	901016-000	E	4.008"	4.750"	901038-000

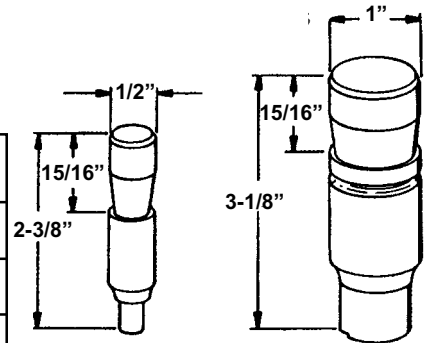

NO. 2

NO. 4

SINGLE STATION DIES

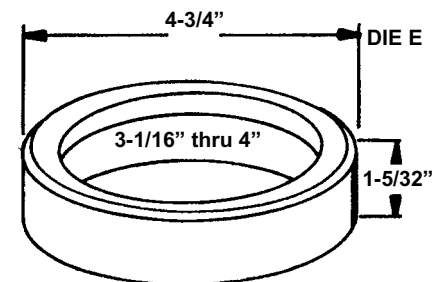
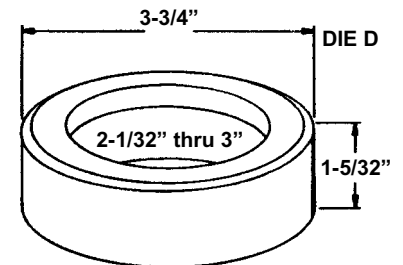
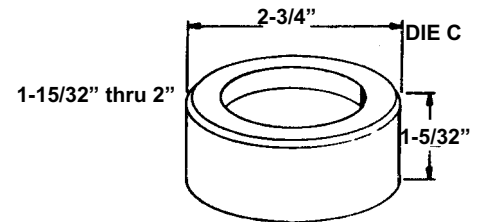
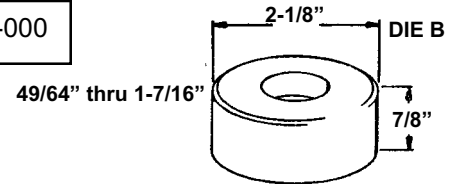
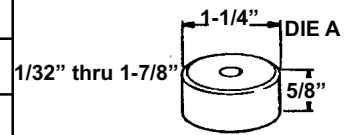

STANDARD SHAPED SERIES

PUNCHES

DIES

STYLE	DIAG. DIMENSION	CAT.NO.	STYLE	MAX DIAG.	O.D.	CAT. NO.
2	.063" - .500"	901048-xxx	A	.508"	1.250"	901070-xxx
4	.501" – 1.000"	901050-xxx	A	.758"	1.250"	901070-xxx
4	1.001" – 1.4375"	901051-xxx	B	1.445"	2.125"	901072-xxx
4	1.438" – 2.000"	901052-xxx	C	2.008"	2.750"	901074-xxx
4	2.001" – 2.500"	901053-xxx	D	2.508"	3.750"	901076-xxx
4	2.501" – 3.000"	901054-xxx	D	3.008"	3.750"	901076-xxx
4	3.001" – 3.500"	901055-xxx	E	3.508"	4.750"	901078-xxx
4	3.501" – 4.000"	901056-xxx	E	4.008"	4.750"	901078-xxx

Common Shape - P.O.R.

*Shaped die openings are within the perimeter of die style dimensions

SINGLE STATION PUNCHES & DIES 901 SERIES

DIE HOLDERS

The die holder is mounted on either the No. 1 or No. 2 Di-Acro punch press, and is available in sizes to accommodate the five die styles. Certain die holders with large I.D. s will utilize dies with a smaller O.D. if fitted with the proper adapter.

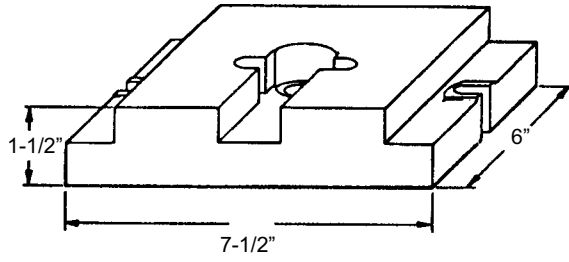

901 SERIES DIE HOLDER

DIE HOLDER STYLE	CAT. NO.	BORE IN HOLDER	ACCOMMODATES DIE STYLE
A	8140150-270	1 1/4"	A
B	8240150-270	2 1/8"	B
C	8040150-270	2 3/4"	C
D	8340150-270	3 3/4"	D
E	8440150-270	4 3/4"	E

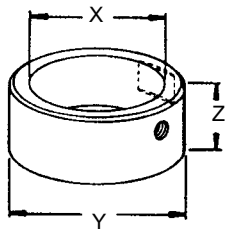

ADAPTER

DIE ADAPTERS

ADAPTER STYLE	CAT. NO.	X	Y	Z	FITS DIE HOLDER
A	8040150-375	1 1/4"	2 3/4"	1 5/32"	C
B	8000150-375	2 1/8"	2 3/4"	1 5/32"	C

K-PRENE® URETHANE STRIPPERS

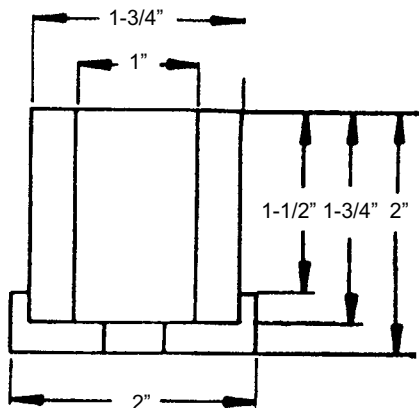
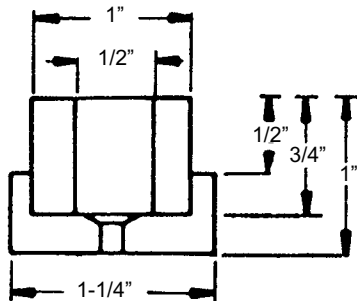

PUNCH HOLDERS

STYLE	CAT. NO.
1"	8040150-102

*Standard with Di-Acro Single Station Punch Nos. 1 and 2.

K-PRENE® URETHANE STRIPPERS

PUNCH STYLE	CAT. NO.	RANGE
2	8273110-280	Up to 1/2"
4	8100100-080	1/2" to 1"

K-PRENE® URETHANE STRIPPERS

PUNCH STYLE	CAT. NO.	RANGE
2	8273110-400	Up to 1/2"
4	8273210-800	1/2" to 1"

902 SERIES NON-KEYED TURRET PUNCHES & DIES

Di-Acro 902 punches and dies are designed for use in Di-Acro No. 12 and No. 18 hand turret punch presses.

TWIN SHEAR- Punches requiring more than 4 tons to punch 16 gauge mild steel (13/16" round or equivalent irregular size) are supplied with twin shear. Twin shear reduces necessary power about 50%. Punches 13/16" or larger are also available without twin shear.

CENTER POINT- Punches 1/8" or more in diameter are supplied with center point. Additional charge to remove center point.

CLEARANCE- Standard clearance is .007"-.008" (15% of 16 ga. material). Special clearance can be supplied if information is provided at the time of order. Special clearances greater than .004" are available at no additional cost.

BLANKING DIES- In operations where the slug is to be retained, Di-Acro can furnish the punch and die sets to your specifications. For blanking, the punch is ground flat.

STANDARD ARRANGEMENT OF ROUND PUNCHES AND DIES- Available for No. 12 and 18 hand punch presses – a package of round punch and die sets in sizes most often used.

PACKAGE 902802-000- includes the following sizes: 1/16", 1/8", 5/32", 3/16", 7/32", 1/4", 5/16", 3/8", 7/16", 1/2", 5/8", 3/4", 13/16", 7/8", 15/16", 1", 1-1/4", AND 1-1/2".



#18 TURRET

PUNCH HOLDERS

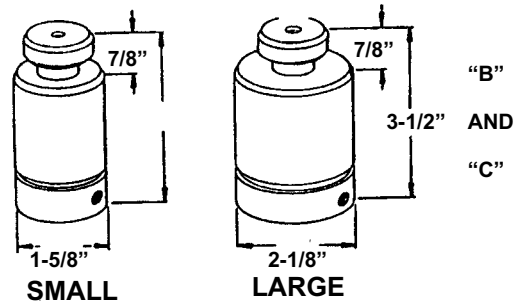

CAT. NO.
902802-000

PUNCH HOLDERS

902 SERIES	CAT. NO.
SMALL	8060150-103
LARGE	8000150-103

DIE HOLDERS

902 SERIES	CAT. NO.
A	8060150-204
B	8000150-204
C	8100150-204

METAL STRIPPERS

SRTIPPER	CAT. NO.
SMALL	8060140-304
LARGE	8000140-304

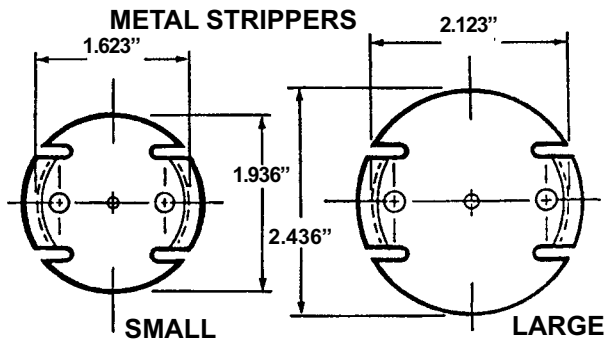
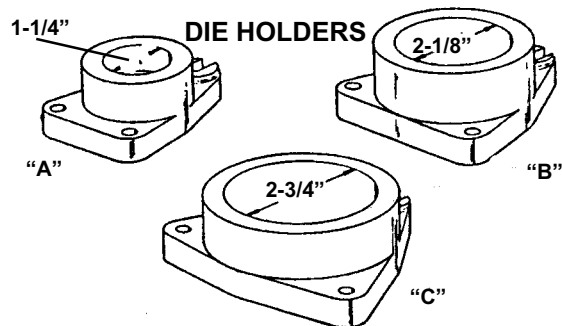

NON-KEYED TURRET PUNCHES & DIES 902 SERIES

PUNCHES

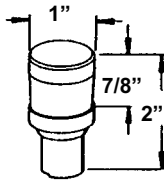

0" to 1"

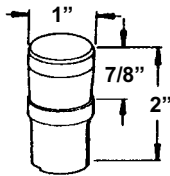

1" to 1-7/16"

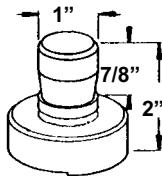

1-7/16" to 2"

DIES

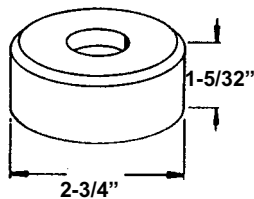
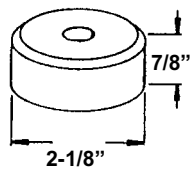
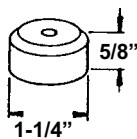

ROUND PUNCHES

STYLE	SIZE	CAT. NO.
A	.063" -- .750"	902010-000
A	.751" – 1.000"	902010-000
B	1.001" – 1.4375"	902012-000
C	1.438" – 2.000"	902014-000

DIES

STYLE	MAX DIAM.	O.D.	CAT. NO.
A	.758"	1.250"	901030-000
B	1.008"	2.125"	901032-000
B	1.445"	2.125"	901032-000
C	2.008"	2.750"	901034-000

STANDARD SHAPED SERIES

PUNCHES

STYLE	DIAG. DIMENSION	CAT. NO.
A	.063" – 1.000"	902050-xxx
B	1.001" – 1.4375"	902052-xxx
C	1.438" – 2.000"	902054-xxx

DIES

STYLE	MAX DIAG.	O.D.	CAT. NO.
A	.758"	1.250"	901070-xxx
B	1.008"	2.125"	901072-xxx
B	1.445"	2.125"	901072-xxx
C	2.008"	2.750"	901074-xxx

Common Shape - P.O.R.

K-PRENE® URETHANE STRIPPERS (ROUNDS & SHAPES)

STATION	SIZE DIAGONAL	CAT. NO.
A	.375"	8902150-800
A	.750"	8002150-800
B	1.000"	8102150-800
B & C	1.625"	8202150-800

903 SERIES KEYED TURRET PUNCHES & DIES

The punches and dies of this series are keyed 0 degree to 90 degree on all shaped tooling. This feature allows for quick alignment of the punches and dies, and insures accurate burr-free punching. Keyed punches and dies must be used with special quick change punch and die holders of the 903 series or the keyed feature is lost.

903 keyed punches and dies are made for use in the Di-Acro models VT-19P, VT-19S, 18E, 18-18 N/C, and the VT-19 N/C with 903 turret. This series tooling can be adapted to the Di-Acro VT-36 stylus and the VT-36 N/C machines through the use of special adapters.



TWIN SHEAR- Punches requiring more than 7 1/2" tons to punch 10 gauge mild steel (13/16" round or equivalent irregular size) are supplied with twin shear. Twin shear reduces necessary power about 50%. Punches 13/16" or larger are also available without twin shear. Consult factory for pricing.

CENTER POINT- Punches 1/8" or more in diameter are supplied with center point. Additional charge to remove center point.

BLANKING DIES- In operations where the slug must be retained, Strippit can furnish punch and die sets to your specifications. For blanking, the punch is ground flat.

PUNCH HOLDERS

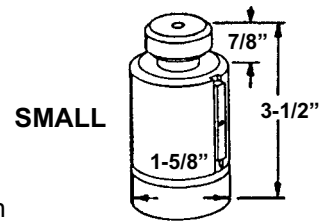

SMALL

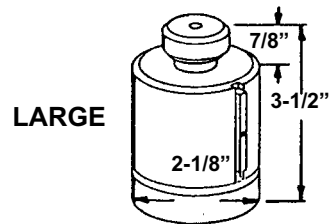

LARGE

PUNCH HOLDERS

903 SERIES	CAT. NO.
SMALL	8066150-170
LARGE	8066150-171

DIE HOLDERS

903 SERIES	CAT. NO.
A	8066150-280
B	8166150-280
C	8266150-280

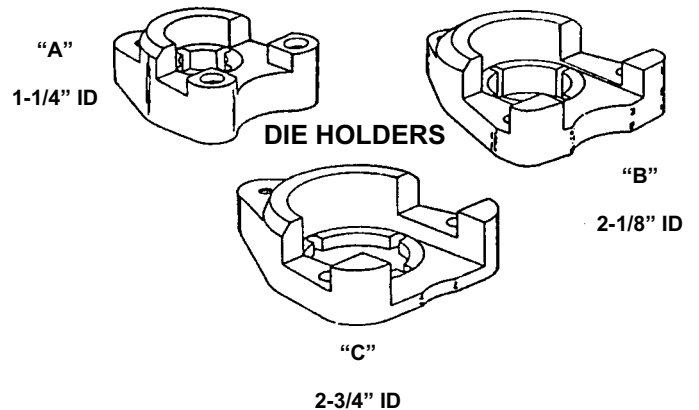

TURRET SPECIFICATIONS

NUMBER OF STATIONS	DIE HOLDER	ROUND DIAM. SIZE RANGE
12	A	0" – 3/4"
5	B	49/64" – 1 7/16"
1	C	1-15/32" – 2"

KEYED TURRET PUNCHES & DIES 903 SERIES

PUNCHES

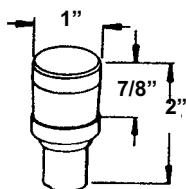

"A"

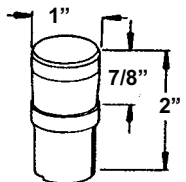

"B"

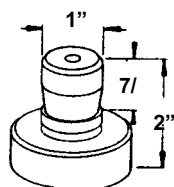

"C"

DIES

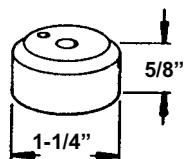

"A"

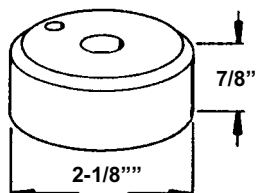

"B"

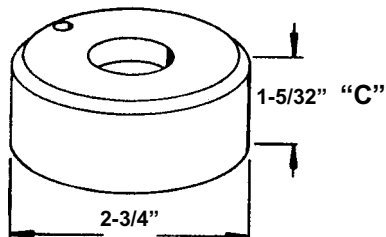

"C"

ROUND PUNCHES

STYLE	SIZE	CAT. NO.
A	.063" - .750"	902010-000
B	.751" - 1.000"	902010-000
B	1.001" - 1.4375"	902012-000
C	1.438" - 2.000"	902014-000

DIES

STYLE	MAX DIAM.	O.D.	CAT. NO.
A	.758"	1.250"	901030-000
B	1.008"	2.125"	901032-000
B	1.445"	2.125"	901032-000
C	2.008"	2.750"	901034-000

STANDARD SHAPED SERIES PUNCHES

STYLE	DIAG. DIMENSION	CAT. NO.
A	.063" - .750"	903050-xxx
B	.751" - 1.000"	903052-xxx
C	1.001" - 1.500"	903054-xxx
C	1.501" - 2.000"	903056-xxx

DIES

STYLE	MAX DIAG.	O.D.	CAT. NO.
A	.758"	1.250"	903070-xxx
B	1.008"	2.125"	903072-xxx
B	1.445"	2.125"	903072-xxx
C	2.008"	2.750"	903074-xxx

Common Shape - P.O.R.

K-PRENE® URETHANE STRIPPERS ROUNDS

STATION	SIZE	CAT. NO.
A	.375"	8902150-800
A	.750"	8002150-800
B	1.000"	8102150-800
B & C	1.500"	8202150-800

SHAPES

STATION	SIZE	CAT. NO.
A	.375"	8302150-800
A	.750"	8402150-800
B	1.125"	8502150-800
B & C	1.500"	8602150-800

905 SERIES ADJUSTABLE PUNCHES & DIES

905 punches and dies are designed for use in Di-Acro Adjustable Die Sets. 905 punches are manufactured without a center point, and do not offer shear. However, this series tooling will adapt to Di-Acro punch presses and other competitive machines (3.500" shut height – 1 1/2" die height).

ROUND

PUNCHES

SERIES	SIZE	CAT. NO.
33	.063" - .375"	905010-000
44	.376" - .625"	905012-000
55	.626" - 1.000"	905014-000
66	1.001" - 1.750"	905016-000

DIES

MAX DIAMETER	O.D.	CAT. NO.
.390"	.625"	905030-000
.640"	1.000"	905032-000
1.015"	1.500"	905034-000
1.765"	2.250"	905036-000

STANDARD SHAPED SERIES

PUNCHES

SERIES	DIAGONAL DIMENSION	CAT. NO.
33	.063" - .375"	905050-xxx
44	.376" - .625"	905052-xxx
55	.626" - 1.000"	905054-xxx
66	1.001" - 1.750"	905056-xxx

DIES

MAX DIAGONAL	O.D.	CAT. NO.
.390"	6.25"	905070-xxx
.640"	1.000"	905072-xxx
1.015"	1.500"	905074-xxx
1.765"	2.250"	905076-xxx

Common Shape - P.O.R.

PUNCHES

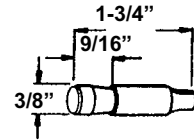

SERIES 33

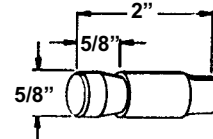

SERIES 44

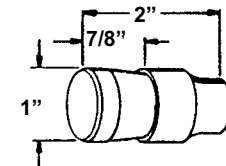

SERIES 55

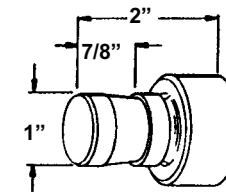

SERIES 66

DIES

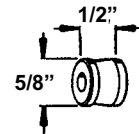

SERIES 33

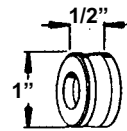

SERIES 44

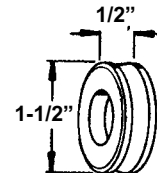

SERIES 55

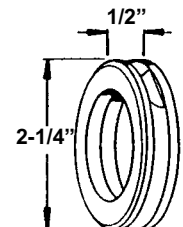

SERIES 66

REPLACEMENT TOOLING & ACCESSORIES **905 SERIES**



K-PRENE® URETHANE STRIPPERS

Can be use where individual stripper are preferred. K-Prene® stirppers are recommended for use on 3/8" (Series 33) and 5/8" (Series 44) shank punches only. Strippers, slipped over punch shank, can be easily removed.

CAT. NO.
8905923-300
8905924-400



PUNCH HOLDERS

CAT. NO.
8905178-330
8905178-440
8905178-550



DIE HOLDERS

CAT. NO.
8905148-330
8905148-440
8905148-550
8901548-660

STANDARD SHAPED SERIES

Rectangle -300



Square -200



Round -000



Single D -400



Oblong -550



Oblong
Center Radius -500



Hexagon -650



COMMON SHAPED SERIES

Elipse -100



Lattice Bar -800



RS-232 -180



RS-232
with slots -190



Keyhole -950



Double Keyhole
with End Radii -120



Keyhole with
End Radius -110



Corner
Radius -170



Jail Bar -195



Teardrop -130



Hotdog -140



Elongated D -150



Gumdrop -160



COMMON SHAPED SERIES

Pentagon -210



Heptagon -220



Octagon -230



Decagon -240



Rhombus -250



Rhomboid -260



Trapezoid -270



Trapezium -280



Equilateral
Triangle -290



Isosceles
Triangle -295



Right
Triangle -310



Scalene
Triangle -320



Point Star -330



L-Shape -340



U-Shape -350



I-Shape -360



Cutler-Hammer™
-370



General Electric™
-380



Square D,
Westinghouse™
-390



Allen Bradley,
Clark, General Electric,
Westinghouse™ -395

