

REVISIONS			
REV	DESCRIPTION	DATE	APPROVED
A	UPDATED DRAWING AND TITLE BLOCK	3/7/05	LW

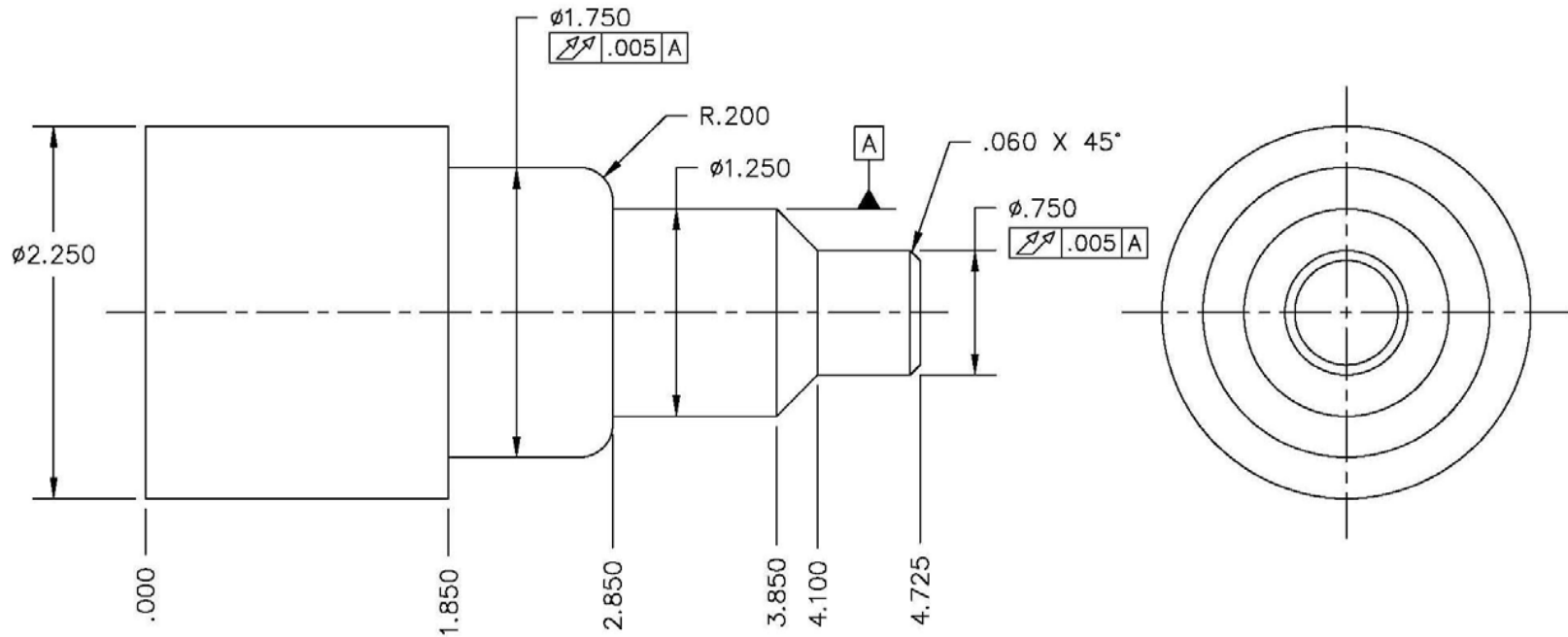

NOTES:

1. CENTER PERMISSIBLE (ϕ .750 END)
2. ALL FILLETS AND RADII .015 INCHES MAXIMUM
3. SURFACE FINISH ALL OVER 63 MICROINCHES MAXIMUM
4. UNLESS OTHERWISE SPECIFIED, ALL COAXIAL DIAMETERS

$\sqrt{\text{A}}$.010 A

		MACHINING SKILLS LEVEL I	
		Job Duty 2.11 CNC: Turning	
DESIGNER	CLC	02/23/02	MATERIAL ALUMINUM OR MILD STEEL
DWG CHK			
DWG APPD			
UNLESS OTHERWISE SPECIFIED DIMENSIONS ARE IN INCHES INTERPRET DIMENSIONS AND TOLERANCES PER ASME Y14.5M-1994			
TOLERANCES .X \pm .020 .XXX \pm .003 .XX \pm .010 ANGLES \pm 1 DEG. FRACTIONS \pm 1/64		SCALE FULL	DWG.#98441 SHEET 1 OF 1

DO NOT SCALE DRAWING

NIMS PROCEDURAL REQUIREMENTS

1. PROGRAM MUST BE WRITTEN IN LONG HAND – NO CAM
2. COORDINATE CALCULATIONS CAN BE FOUND WITH GEOMETRY OR TRIG
3. SUBMIT THE CALCULATIONS WITH THE PROGRAM
4. SUBMIT THIS PRINT, COPY OF PROGRAM CODE (LONGHAND), AND WORKPIECE ALONG WITH THE PERFORMANCE AFFIDAVIT FOR EVALUATION